

# QT060

## Liquid Cooled Gas Engine Generator Sets

Standby Power Rating  
60 kW 60 Hz

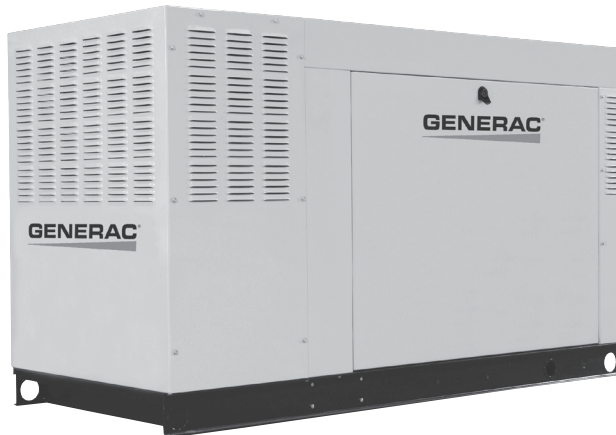

### GENERAC 2.4L ENGINE

Turbocharged/Aftercooled  
Gaseous Fueled  
Meets 2009 EPA Emission Regulations

## STANDARD EQUIPMENT

- All input connections in one single area
- High coolant temperature shutdown
- Low oil pressure shutdown
- Low coolant level automatic shutdown
- Overspeed automatic shutdown
- Crank timer
- Exercise timer
- Oil drain extension
- Cool flow radiator
- Closed coolant recovery system
- UV/Ozone resistant hoses
- Watertight state of the art electrical connectors
- Mainline circuit breaker
- Radiator drain extension
- Battery charge alternator
- 2 Amp static battery charger
- Battery cables
- Battery rack
- Fan and belt guards
- Isochronous governor
- Flex fuel line
- Hour meter

## FEATURES

- Innovative design and fully prototype tested
- UL2200 Listed
- Solid state frequency compensated voltage regulator
- Dynamic and static battery charger
- Sound attenuated acoustically designed enclosure
- Quiet test for low noise level exercise
- Acoustically designed engine cooling system
- High flow low noise factory engineered exhaust system
- State of the art digital control system with R100 digital control panel
- Watertight electrical connectors
- Rodent proof construction
- High efficiency, low distortion Generac designed alternator
- Vibration isolated from mounting base
- Matching Generac transfer switches engineered and tested to work as a system
- All components easily accessible for maintenance
- Electrostatically applied powder paint

# GENERAC®

# APPLICATION & ENGINEERING DATA

QT060

## GENERATOR SPECIFICATIONS

TYPE .....	Synchronous
ROTOR INSULATION.....	Class H
STATOR INSULATION.....	Class H
TOTAL HARMONIC DISTORTION.....	<5%
TELEPHONE INTERFERENCE FACTOR (TIF) .....	<50
ALTERNATOR OUTPUT LEADS 3 PHASE .....	4 wire
BEARINGS.....	Sealed Ball
COUPLING.....	Flexible Disc
LOAD CAPACITY (STANDBY RATING).....	60 kW
EXCITATION SYSTEM.....	Direct

**NOTE:** Generator rating and performance in accordance with ISO8528-5, BS5514, SAE J1349, ISO3046, and DIN6271 standards.

## VOLTAGE REGULATOR

TYPE .....	Electronic
SENSING .....	Single Phase
REGULATION.....	± 1%
FEATURES.....	V/F Adjustable Adjustable Voltage and Gain LED Indicators

## GENERATOR FEATURES

- Revolving field heavy duty generator
- Directly connected to the engine
- Operating temperature rise 120 °C above a 40 °C ambient
- Insulation is Class H rated at 150 °C rise
- All models are fully prototyped tested

## CONTROL PANEL FEATURES

- |  |  |
|--|--|
| <input type="checkbox"/> SEVEN LED INDICATOR LIGHTS <ul style="list-style-type: none"><li>• System ready</li><li>• Low fuel pressure</li><li>• Low battery</li><li>• Low oil pressure</li><li>• High coolant temp/low coolant temp</li><li>• Overspeed</li><li>• Overcrank</li></ul> | <input type="checkbox"/> ADDITIONAL FUNCTIONS <ul style="list-style-type: none"><li>• Utility sensing</li><li>• Delay on utility failure for engine start</li><li>• Engine warm-up before transfer</li><li>• Delay to retransfer to utility</li><li>• Engine cooldown timer</li><li>• Exerciser not set</li><li>• Hour meter</li></ul> |
|--|--|
- INTERNAL FUNCTIONS:
- 3 position switch (auto, off and manual)
  - 2 wire start for any transfer switch
  - Communicates with the Generac RTS transfer switch
  - Built-in 7 day exerciser
  - Selectable engine speed at exercise
  - Governor controller is built into the master control board
  - Temperature range -40 °C to 70 °C

## ENGINE SPECIFICATIONS

MAKE .....	Generac
MODEL.....	2.4 Liter
CYLINDERS.....	Inline 4
DISPLACEMENT.....	2.4 Liter
BORE.....	3.41
STROKE.....	3.94
COMPRESSION RATIO.....	8.5:1
INTAKE AIR SYSTEM.....	Turbocharged/Aftercooled
VALVE SEATS.....	Hardened
LIFTER TYPE.....	Hydraulic

## GOVERNOR SPECIFICATIONS

TYPE .....	Electronic
FREQUENCY REGULATION.....	± Isochronous
STEADY STATE REGULATION.....	± 0.25%
ADJUSTMENTS FOR:	
Speed .....	Yes
Droop.....	Yes

## ENGINE LUBRICATION SYSTEM

OIL PUMP .....	Gear
OIL FILTER.....	Full flow spin-on cartridge
CRANKCASE CAPACITY.....	4 Quarts

## ENGINE COOLING SYSTEM

TYPE .....	Closed
WATER PUMP.....	Belt driven
FAN SPEED.....	2100
FAN DIAMETER.....	22 inches
FAN MODE.....	Puller

## FUEL SYSTEM

FUEL TYPE.....	Natural gas, propane vapor
CARBURETOR.....	Down Draft
SECONDARY FUEL REGULATOR.....	Standard
FUEL SHUT OFF SOLENOID .....	Standard
OPERATING FUEL PRESSURE.....	5" - 14" H <sub>2</sub> O

## ELECTRICAL SYSTEM

BATTERY CHARGE ALTERNATOR.....	12V 30 Amp
STATIC BATTERY CHARGER .....	2 Amp
RECOMMENDED BATTERY .....	Group 26, 525CCA
SYSTEM VOLTAGE.....	12 Volts

## OPERATING DATA

		QT060		
<b>KW RATING</b>		60		
<b>ENGINE SIZE</b>		2.4 Liter		
<b>GENERATOR OUTPUT VOLTAGE/KW - 60Hz</b>		<b>KW</b>	<b>AMP</b>	<b>CB Size</b>
120/240V, 1-phase, 1.0 pf		60	250	300
120/208V, 3-phase, 0.8 pf		60	208	250
120/240V, 3-phase, 0.8 pf		60	180	200
277/480V, 3-phase, 0.8 pf		60	90	100
<b>GENERATOR LOCKED ROTOR KVA AVAILABLE @ VOLTAGE DIP OF 35%</b>				
Single phase or 208/240 3-phase		120		
480V 3-phase		141		
<b>ENGINE FUEL CONSUMPTION (Natural Gas) (Propane)</b>		<b>Natural Gas</b>	<b>Propane</b>	
		(ft <sup>3</sup> /hr.)	(gal/hr.)	cu ft/hr
Exercise cycle		123	1.34	49.3
25% of rated load		267	2.7	101
50% of rated load		483	5.0	183
75% of rated load		672	7.0	255
100% of rated load		862	9.0	327
<b>ENGINE COOLING</b>				
Air flow (inlet air including alternator and combustion air) ft <sup>3</sup> /min.		3,280		
System coolant capacity US gal.		2.5		
Heat rejection to coolant BTU/hr.		270,000		
Max. operating air temp. on radiator °C (°F)		60 (150)		
Max. ambient temperature °C (°F)		50 (140)		
<b>COMBUSTION AIR REQUIREMENTS</b>				
Flow at rated power 60 Hz cfm		180		
<b>SOUND EMISSIONS IN DBA</b>				
Exercising at 7 meters		65		
Normal operation at 7 meters		72		
<b>EXHAUST</b>				
Exhaust flow at rated output 60 Hz cfm		494		
Exhaust temp. at muffler outlet °F		1,050		
<b>ENGINE PARAMETERS</b>				
Rated synchronous RPM 60 Hz		3600		
HP at rated KW 60 Hz		94		
<b>POWER ADJUSTMENT FOR AMBIENT CONDITIONS</b>				
Temperature Deration				
3% for every 10 °C above - °C		25		
1.65% for every 10 °F above - °F		77		
Altitude Deration				
1% for every 100 m above - m		915		
3% for every 1000 ft. above - ft.		3000		

RATING: All three phases units are rated at 0.8 power factor. All single phase units are rated at 1.0 power factor. STANDBY RATING: Standby ratings apply to installations served by a reliable utility source. The standby rating is applicable to varying loads for the duration of a power outage. There is no overload capability for this rating. Ratings are in accordance with ISO-3046-1. Design and specifications are subject to change without notice.

# INTERCONNECTIONS

QT060

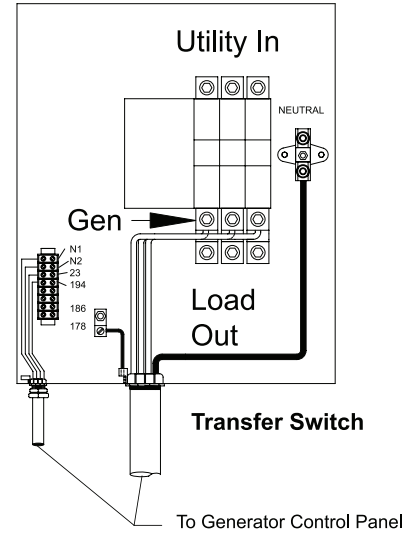
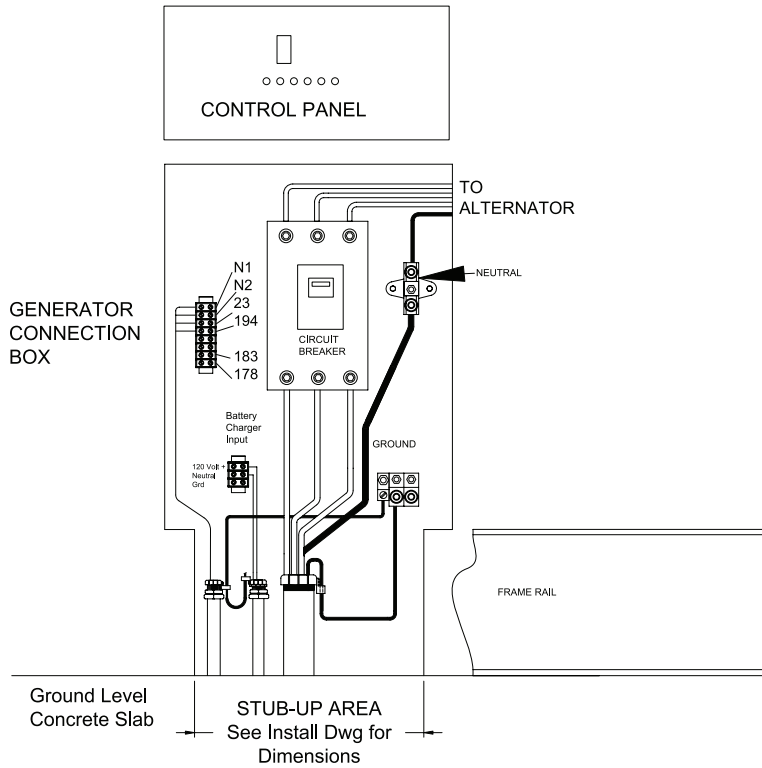

### CIRCUIT BREAKER SIZE

kW	VOLTS	/	AMPS	LUG SIZE
60	240	1 $\phi$	300	(2) 250 mcm to 2 - 1/0 or (1) 600 mcm to #4
60	208	3 $\phi$	250	(2) 250 mcm to 2 - 1/0 or (1) 600 mcm to #4
60	240	3 $\phi$	200	#6 to 300 mcm
60	480	3 $\phi$	100	#6 to 300 mcm

Installation Drawing Ref. No. 0F9577

# INSTALLATION LAYOUT

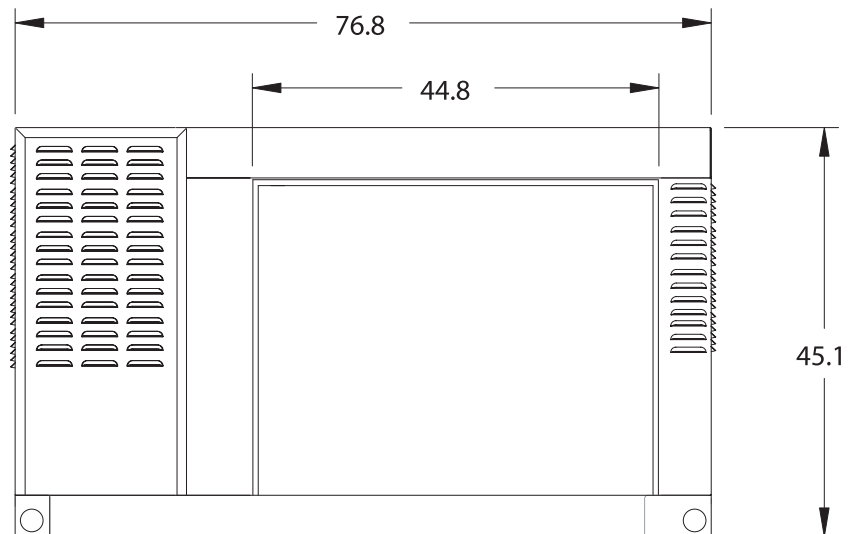
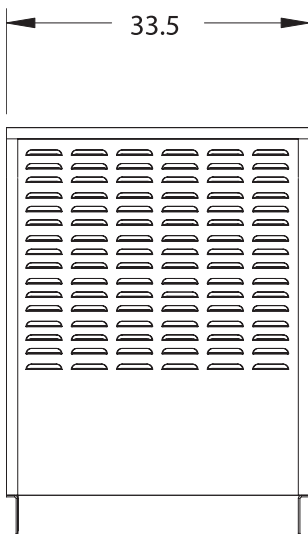

**WEIGHT: 1650 lbs.**



Generac Power Systems, Inc. • S45 W29290 HWY. 59, Waukesha, WI 53189 • generac.com

©2009 Generac Power Systems, Inc. All rights reserved. All specifications are subject to change without notice. Bulletin 0177740SBY/Printed in U.S.A. 06.08, rev: 09.09